

STRONGPOST[®]

POLYBASE[®]

**Product Manual
and Installation Guide**



Table of Contents

Product Description.....	2
Technical Specifications.....	3
Technical Drawings.....	3
StrongPost® Base Support Variations.....	4
Maximum Allowable Load Charts.....	7
Site Assessment.....	8
StrongPost® Preparation.....	9
PolyBase® Installation.....	10
Step-by-step StrongPost® Installation with Polybase®.....	12
Base Mount Installation with CIP Pad.....	14
StrongPost Joist Connection Variations.....	16
Saddle Bracket.....	16
Top Plate.....	19
I-Beam Saddle Bracket for Metal Girders.....	20

POLYBASE® / STRONGPOST®

Product Description

StrongPost® is a vertical interior structural support pier installed within the confines of a crawlspace to provide interior structural support for a building's floor system. An existing wood frame floor system may give or sag over time as a result of poor or settling soils, contractor mistakes, engineer/architect errors, material deterioration, having too long unsupported span lengths or weakening of the wooden floor joists due to the exposure in high moisture conditions typical in crawl space environments.

The StrongPost® System is designed to fit within any crawlspace. It is the strongest, most labor and material saving, lean-construction heavy duty column support system of its kind currently available. The system is designed, engineered, and tested to lift, stabilize, and provide the best supplemental solution to permanently strengthening the structure's floor system.

Features:

- Accommodates Limited Access Crawlspaces
- A Professionally Engineered Solution
- Galvanized Steel Components
- Immediate Floor System Stabilization
- Independently Certified
- High-Strength Polymer Concrete
- Built-In Quality Control
- Corrosion Resistant
- Moisture Proof
- Structurally Rated
- Termite-Proof

Advantages:

- No Excavation Required for most PolyBase® applications
- Ease of Installation
- Labor Saving
- Modular Components
- Multi-Functional
- All-Thread Rod is locked into place, but capable of future adjustments

TECHNICAL SPECIFICATIONS

All StrongPost® components are manufactured utilizing the following material criteria:

- Plate/Bar Material: **ASTM A-36 steel or better** (i.e. A-572)
- 2.875" Cross-Sectional Tube/Pipe Material: **Structural steel tube or pipe, seamless or welded ASTM A500 Grade B or ASTM A53 Grade A**
- Galvanizing: **Galvanized as per ASTM A153**

TECHNICAL DRAWINGS

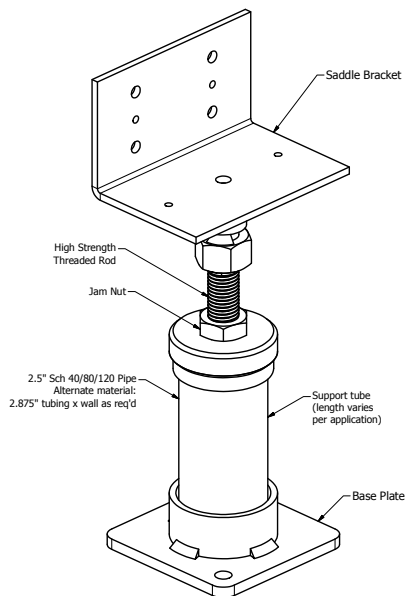

2.875" SADDLE BRACKET SUPPORT FOR WOODEN JOISTS

4.5" Adjustment Range
Overall Height Variable From 10" To 91"
(Dependent On Support Tube Length)

30,000 lbf Load Capacity*
Assembly Weight = 13.2 lb
Plus Support Pipe Weight

*Capacity Varies w/ Pipe Cross-Section & Length Utilized, As Well As Underlying Soil Strength

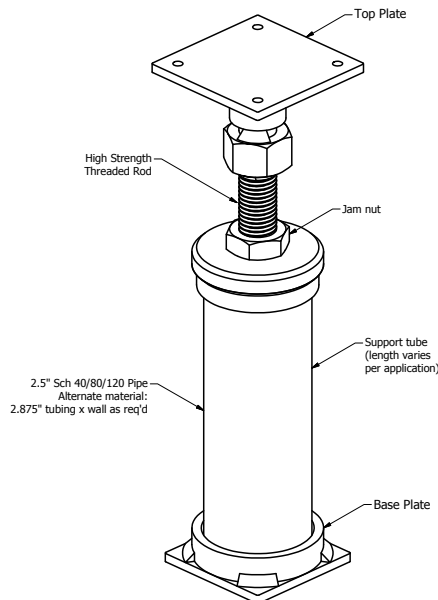

2.875" TOP PLATE SUPPORT FOR WOODEN FLOOR JOISTS

4.5" Adjustment Range
Overall Height Variable From 10" To 91"
(Dependent On Support Tube Length)

30,000 lbf Load Capacity*
Assembly Weight = 9.83 lb
Plus Support Pipe Weight

*Capacity Varies w/ Pipe Cross-Section & Length Utilized, As Well As Underlying Soil Strength

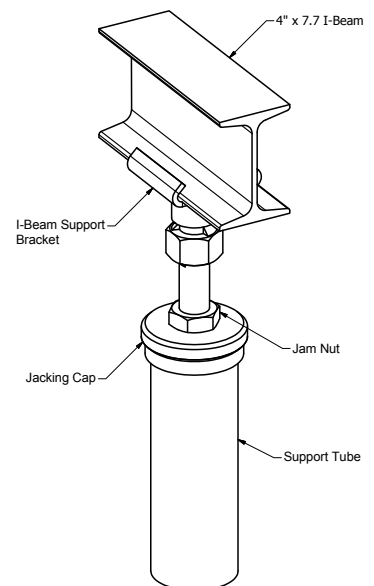

2.875" STRONGPOST ASSEMBLY w/ I-BEAM SADDLE FOR METAL GIRDERS

4.5" Adjustment Range
Overall Height Variable From 10" To 91"
(Dependent On Support Tube Length)

30,000 lbf Load Capacity*
Assembly Weight = 9.83 lb
Plus Support Pipe Weight

*Capacity Varies w/ Pipe Cross-Section & Length Utilized, As Well As Underlying Soil Strength

NOTES:

- Depending upon the results of the Site Assessment, implement the StrongPost® and concrete base plate foundation plan accordingly.
- Consult StrongPost® System Pipe Load Chart for pipe load capacities.
- Load values are based upon an allowable presumptive design soil bearing pressure of 2,000PSF. If weaker soil conditions are encountered, extend the footing to a suitable material or consult a certified professional.
- StrongPost® is intended to provide additional support to existing framing. No lifting is anticipated.

StrongPost® Base Support Variations

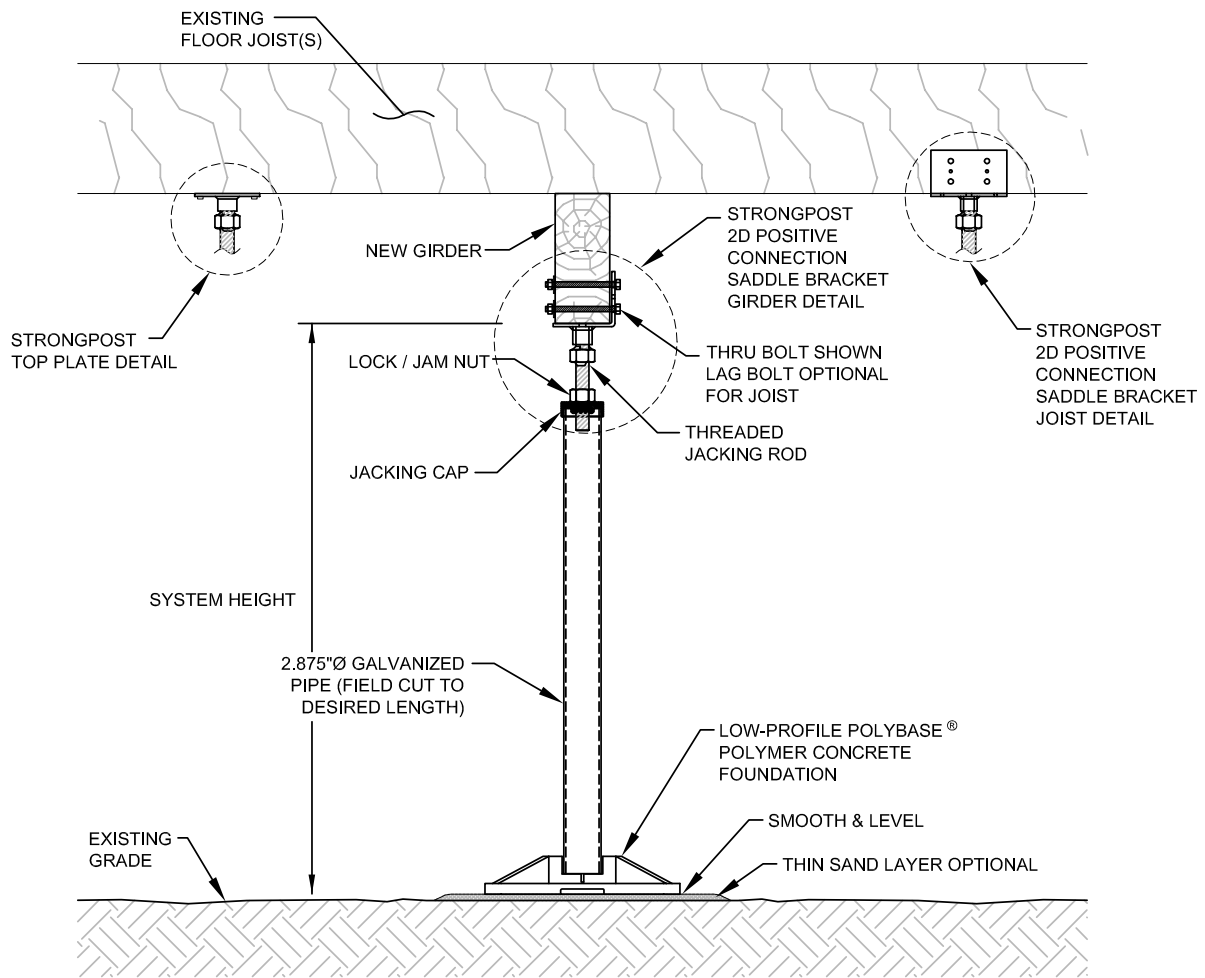

STRONGPOST® FLOOR JOIST SYSTEM

NOT TO SCALE

NOTES:

1. GROUND TO BE AS SMOOTH AND LEVEL AS POSSIBLE.
2. DEPENDING UPON THE RESULTS OF THE SITE ASSESSMENT, IMPLEMENT THE POLYBASE® FOUNDATION PLAN ACCORDINGLY.
3. CONSULT STRONGPOST® SYSTEM PIPE LOAD CHART FOR PIPE CAPACITIES
4. THERE IS AN ALLOWABLE PRESUMPTIVE DESIGN SOIL BEARING PRESSURE OF 2,000 PSF. IF WEAKER SOIL CONDITIONS ARE ENCOUNTERED, EXTEND THE FOOTING TO A SUITABLE MATERIAL OR CONSULT A CERTIFIED PROFESSIONAL.
5. STRONGPOST® IS INTENDED TO PROVIDE ADDITIONAL SUPPORT TO EXISTING FRAMING. NO LIFTING IS ANTICIPATED.



1350 PROGRESS INDUSTRIAL BLVD.
LAWRENCEVILLE, GA 30043
TEL: (678-392-3972

DETAILS

STRONGPOST JOIST SYSTEM

2.875"Ø PIPE CROSS-SECTION

BHEET
DT1
OF 3
ISSUE DATE:
05/07/24
PROJECT NO.:
Z17-0012

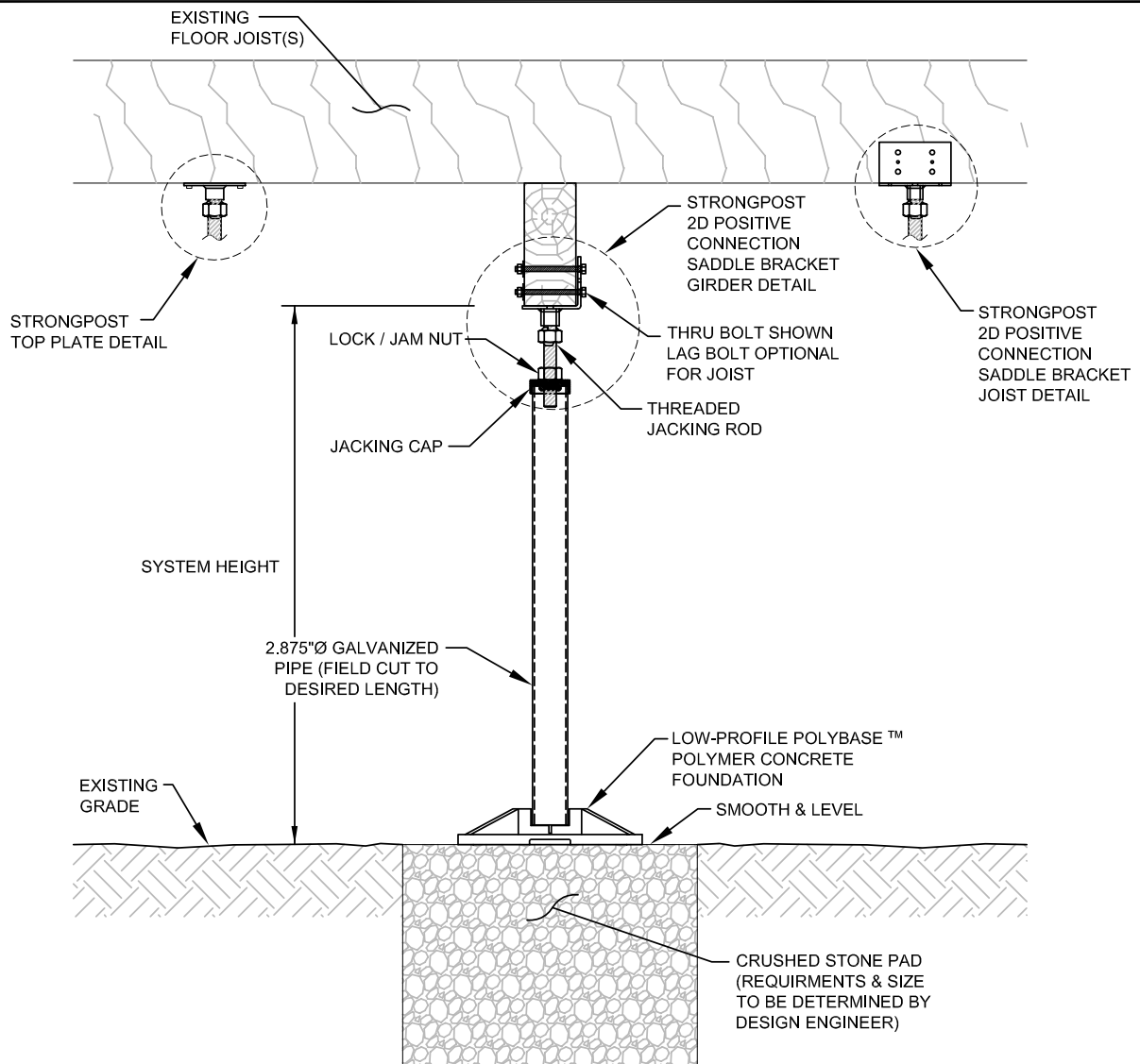

STRONGPOST® FLOOR JOIST SYSTEM WITH STONE PAD

NOT TO SCALE

NOTES:

1. GROUND TO BE AS SMOOTH AND LEVEL AS POSSIBLE.
2. DEPENDING UPON THE RESULTS OF THE SITE ASSESSMENT, IMPLEMENT THE POLYBASE® FOUNDATION PLAN ACCORDINGLY.
3. CONSULT STRONGPOST® SYSTEM PIPE LOAD CHART FOR PIPE CAPACITIES
4. THERE IS AN ALLOWABLE PRESUMPTIVE DESIGN SOIL BEARING PRESSURE OF 2,000 PSF. IF WEAKER SOIL CONDITIONS ARE ENCOUNTERED, EXTEND THE FOOTING TO A SUITABLE MATERIAL OR CONSULT A CERTIFIED PROFESSIONAL.
5. STRONGPOST® IS INTENDED TO PROVIDE ADDITIONAL SUPPORT TO EXISTING FRAMING. NO LIFTING IS ANTICIPATED.



1350 PROGRESS INDUSTRIAL BLVD.
LAWRENCEVILLE, GA 30043
TEL: (678-392-3972

DETAILS

STRONGPOST JOIST SYSTEM
2.875"Ø PIPE CROSS-SECTION

SHEET
DT2
OF 3
ISSUE DATE:
05/07/24
PROJECT NO.:
Z17-0012

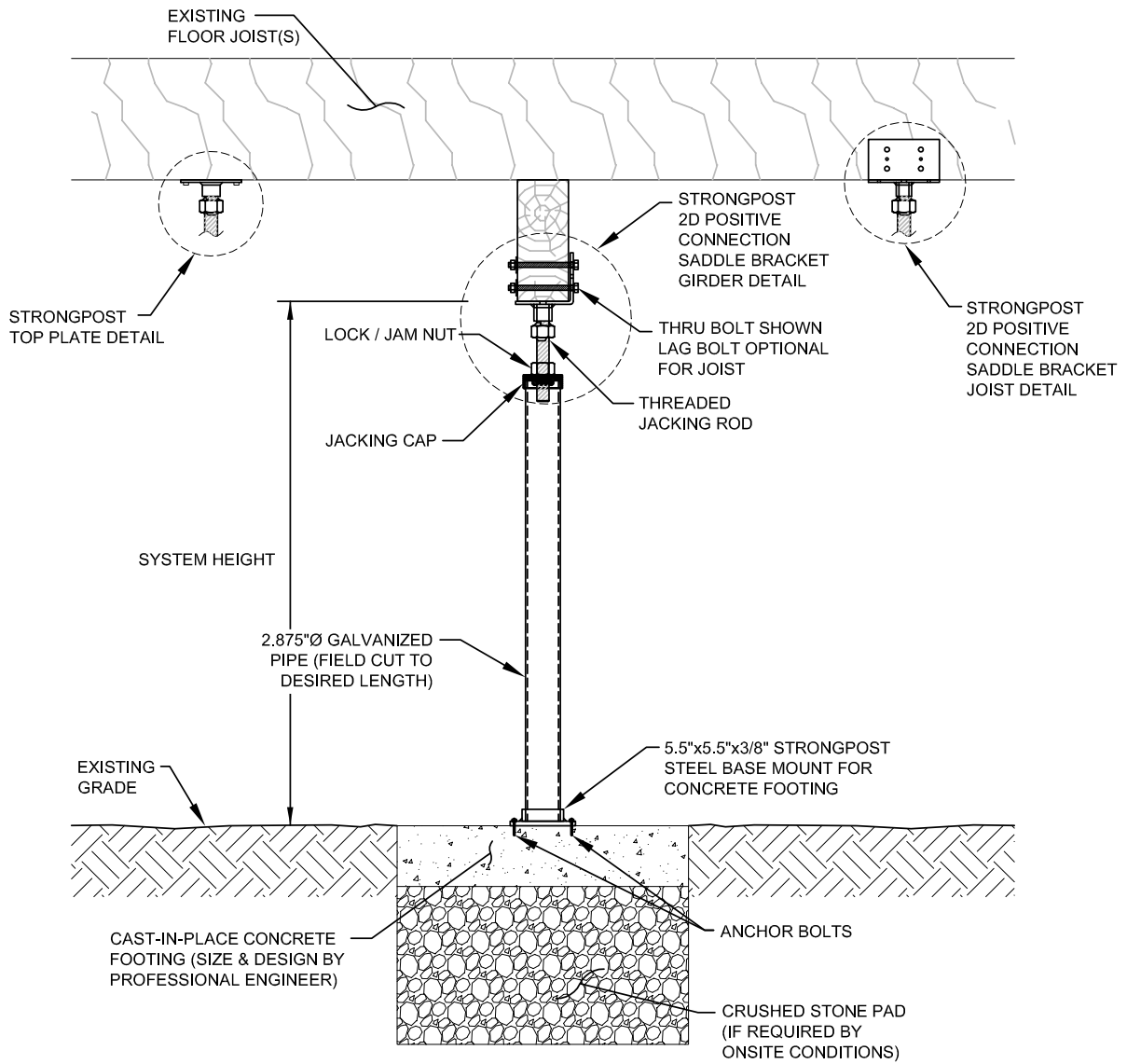

STRONGPOST® FLOOR JOIST SYSTEM WITH CIP PAD
NOT TO SCALE

NOTES:

- | | |
|---|---|
| <ol style="list-style-type: none"> 1. DEPENDING UPON THE RESULTS OF THE SITE ASSESSMENT, INSTALL CONCRETE FOOTING AS PER THE ENGINEER OF RECORD. 2. DEPENDING UPON THE RESULTS OF THE SITE ASSESSMENT, IMPLEMENT THE STEEL BASE MOUNT ACCORDINGLY. 3. CONSULT STRONGPOST® SYSTEM PIPE LOAD CHART FOR PIPE CAPACITIES | <ol style="list-style-type: none"> 4. THERE IS AN ALLOWABLE PRESUMPTIVE DESIGN SOIL BEARING PRESSURE OF 2,000 PSF. IF WEAKER SOIL CONDITIONS ARE ENCOUNTERED, EXTEND THE FOOTING TO A SUITABLE MATERIAL OR CONSULT A CERTIFIED PROFESSIONAL. 5. STRONGPOST® IS INTENDED TO PROVIDE ADDITIONAL SUPPORT TO EXISTING FRAMING. NO LIFTING IS ANTICIPATED. |
|---|---|



1350 PROGRESS INDUSTRIAL BLVD.
LAWRENCEVILLE, GA 30043
TEL: (678-392-3972

DETAILS

STRONGPOST JOIST SYSTEM
2.875"Ø PIPE CROSS-SECTION

SHEET
DT3
OF 3
ISSUE DATE:
05/07/24
PROJECT NO.:
Z17-0012

MAXIMUM ALLOWABLE LOAD CHARTS

2.875" STRONGPOST W/ .165 WALL

<u>PIPE LENGTH</u>	<u>MAX ALLOWABLE LOAD</u>
1'-0"	18,000 LB'S
2'-0"	18,000 LB'S
3'-0"	17,000 LB'S
4'-0"	16,000 LB'S
5'-0"	14,000 LB'S
6'-0"	12,000 LB'S
7'-0"	10,000 LB'S

2.875" STRONGPOST W/ .217 WALL

<u>PIPE LENGTH</u>	<u>MAX ALLOWABLE LOAD</u>
1'-0"	30,000 LB'S
2'-0"	30,000 LB'S
3'-0"	29,000 LB'S
4'-0"	27,000 LB'S
5'-0"	25,000 LB'S
6'-0"	23,000 LB'S
7'-0"	21,000 LB'S

2.875" STRONGPOST W/ .203 WALL

<u>PIPE LENGTH</u>	<u>MAX ALLOWABLE LOAD</u>
1'-0"	29,000 LB'S
2'-0"	29,000 LB'S
3'-0"	28,000 LB'S
4'-0"	26,000 LB'S
5'-0"	24,000 LB'S
6'-0"	22,000 LB'S
7'-0"	20,000 LB'S

2.875" STRONGPOST W/ .276 WALL

<u>PIPE LENGTH</u>	<u>MAX ALLOWABLE LOAD</u>
1'-0"	38,000 LB'S
2'-0"	38,000 LB'S
3'-0"	36,000 LB'S
4'-0"	34,000 LB'S
5'-0"	32,000 LB'S
6'-0"	30,000 LB'S
7'-0"	28,000 LB'S



04/09/2024
Michael DeLoach Jr.
(770) 868-9608

- 1) Loads based on strength of pipe section only
- 2) All loads are un-factored

The allowable loads applied to the StrongPost® system may be limited by the bearing capacity of the existing soil. Well-compacted crushed stone is proven to increase support and improve capacity of weak soils when utilized in tandem with the PolyBase® precast polymer concrete or beneath a CIP concrete footing.

In addition, StrongPost® load capacities are limited to the cross-sectional area, type and length of the pipe utilized within the system. Consult StrongPost® System Maximum Allowable Load Charts for pipe load capacities.

SITE ASSESSMENT

It is recommended that a geotechnical engineering professional examine the soils of the interior earthen floor prior to selecting the appropriate StrongPost® to be used. The StrongPost® system capacity is based upon an assumptive design industry standard of 2,000psf soil for support. If the exposed surface soils directly beneath the anticipated position of the StrongPost® system meets this assumed requirement, then the engineered high-strength PolyBase® precast polymer concrete foundation may be placed directly upon the exposed soil. Most crawlspace sub-soil conditions will meet or exceed this criterion and accommodate the PolyBase® installation (see installation instructions for surface preparation prior to PolyBase® placement.)

Sometimes homeowners are unaware of water pipe leaks that have developed over time. If pipe leaks are observed, then the homeowner should be advised to fix the leaks prior to any support installation. Occasionally, water resulting from poor exterior surface drainage or an underground spring weakens the supporting soils. Should water issues appear evident, then engineered subsurface preparation techniques need to be followed.

If the exposed soil does not meet the 2,000 psf assumed strength criteria but appears to be of sufficient strength to support the StrongPost®, the engineer may recommend removal of some soft soil and replacement with crushed stone. The StrongPost® system can be installed with the Polybase® placed directly on the crushed stone.

Should the engineer elect to substitute a poured concrete footing, the StrongPost® can be installed directly to the cured concrete surface by utilizing the StrongPost® Base Mount. The Base Mount can then be anchored to the poured concrete foundation with the provided anchor bolts. (The poured concrete foundation option will require an additional remobilization to install and anchor the StrongPost®.)

Should rock be encountered beneath where the StrongPost® is to be installed, it is recommended that a quick-setting 2x2 foot concrete base, having a compressive strength of 3000 psi and a minimum 4 inches thickness, be poured over the rock directly underneath where the StrongPost® is to be installed to create a uniform bearing surface. Prior to the placement of the high strength quick setting concrete, the rock surface area beneath the concrete base is to be cleaned of all loose soil and debris. The StrongPost® system should never be placed directly upon rock or boulders encountered due to uneven support of the exposed rock and the uncertainties beneath and around the rock.

If rock or small boulders are encountered, they should be removed from beneath the bearing surface of the precast PolyBase® or concrete footer. It is imperative that the bearing surface beneath the StrongPost® not have irregularities, to prevent eccentric and point loading of the foundation type selected.

STRONGPOST® PREPARATION



Using a plumb bob, determine area of placement directly beneath the center of the joist.



Measure from joist to bearing surface (Polybase®) to determine length of pipe.



Using a chop saw, cut pipe square to the necessary length.



Ensure both ends of the pipe are cut square to provide a uniform bearing surface.

POLYBASE® INSTALLATION

Utilization of the PolyBase® in the direct-to-soil application or placement onto a crushed stone application affords the contractor the ability to complete the installation in one day, thus providing substantial cost savings in time and labor.

PolyBase® Connection Detail

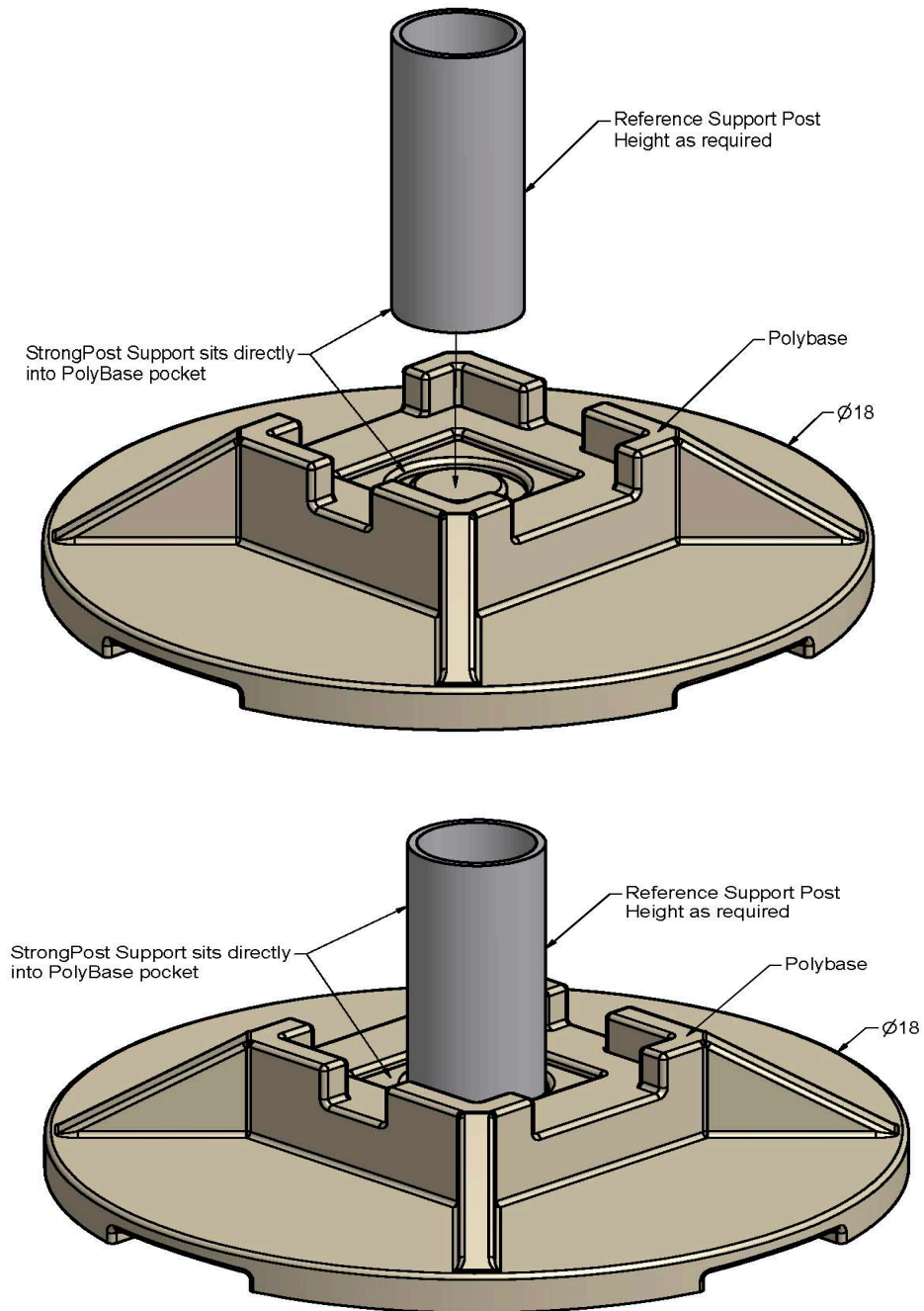

2.875" STRONGPOST® SUPPORT ASSEMBLED DIRECTLY TO 18" POLYBASE®

PolyBase® is designed to receive the StrongPost® pipe support directly within the formed pipe recess. By utilizing direct bearing on the base, the need for a base plate can be eliminated. However, PolyBase® is formed with a base plate recession and is capable of receiving a base plate if specified.



PolyBase® can be installed directly on level soil.



Pipe assembled directly to 18" PolyBase®.

2.875" STRONGPOST® CONCRETE BASE MOUNT ASSEMBLED TO 18" POLYBASE®

In addition, PolyBase® is formed and capable of receiving a much larger base plate providing additional lateral stability. The Concrete Base Mount Plate is interchangeable in this application.



PolyBase® installed on 57 stone.



Pipe assembled with Base Mount.

STRONGPOST® INSTALLATION WITH POLYBASE®



1. Prepare the area beneath the StrongPost® to receive the floor stabilization system.

2. Place PolyBase® onto the prepared surface, and center to the floor joist or girder using a plumb bob.



3. Level PolyBase®.
(Tip: a layer of sand will help in leveling if there are irregularities in the prepared surface.)

4. Measure the length between the installed PolyBase® pipe seat and the girder or joist to be supported and cut pipe to measured length.

It is important to cut the ends square to provide a uniform bearing surface on both ends of the pipe.

*Cutting the pipe 1-3" shorter than the measured overall length of the support will make installation easier.

Vertical adjustment length should not exceed 4 inches.





5. Assemble the StrongPost® System. Adjust the provided locking nut all the way up the length of the Threaded Jacking Rod prior to connecting all components. Connect all StrongPost® components and insert into the Saddle Bracket pipe sleeve and onto the PolyBase® pipe seat, leaving room for adjustment. Ensure pipe is centered beneath the center of the joist to be supported.

6. Move assembled StrongPost® into place, then attach the saddle bracket to the new girder or existing floor joist utilizing supplied lag bolts and wood screws.

Note: For single joists, utilize wood spacer blocking (see page 17). When affixing saddle bracket to a wooden girder, thru bolts are recommended (see page 18).



7. Once the system is in place, turn the adjusting nut on the threaded jacking rod to place a stabilizing load on the Polybase® against the soil. Release the load by backing the adjusting nut down, then re-engage the load by turning the adjusting nut to the desired position of stabilization.

8. After load and positioning has been achieved, tighten the locking nut against the top of the Jacking Cap surface to lock system and complete installation.



JOIST SYSTEM WITH CIP PAD

StrongPost® can be installed on a cast-in-place (CIP) concrete pad when required.

Base Mount with CIP Pad Connection Detail

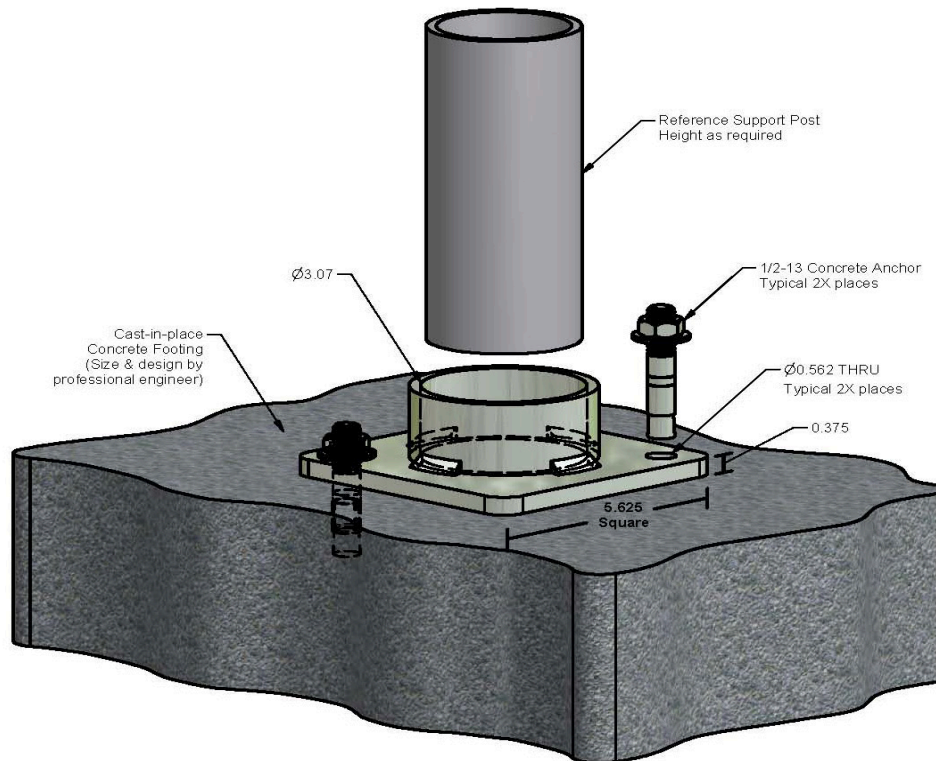

STRONGPOST® & CIP PAD INSTALLATION

Install a crushed stone pad beneath the area where the Cast-In-Place concrete pad is to be poured if so required. Dig and pour the Cast-In-Place concrete footing sized and designed by a professional engineer, ensuring a smooth surface area for the Base Mount to be placed. After curing, follow StrongPost® installation instructions, utilizing the Base Mount in place of Polybase®.



Anchor bolts installed into concrete footer.



Base Mount installed on concrete footer.



Assembled system on concrete footer.

STRONGPOST® CIP BASE PLATE INSTALLATION SEQUENCE:

Note: Refer to installation photos on pages 12 and 13.

- A. Install a crushed stone pad beneath the area where the Cast-In-Place (CIP) concrete pad is to be poured if so required.
- B. Dig and pour the CIP concrete footing sized and designed by a professional engineer, ensuring a smooth and level surface area for the StrongPost® Base Mount to receive the floor stabilization system. Allow CIP concrete pad to cure.
- C. Use a plumb bob to position the StrongPost® Base Mount on the CIP pad under the center of the floor joist or girder to receive the StrongPost® system.
- D. Measure the length between the floor joist or girder and the StrongPost® Base Mount.
- E. Cut the pipe 1-3" shorter than the measured length to make installation easier. *Vertical adjustment length should not exceed 4 inches. It is important to cut the ends square to provide a uniform bearing surface on both ends of the pipe.*
- F. Assemble the StrongPost® System together for ease of installation. Run the locking nut provided all the way up the length of the Threaded Jacking Rod prior to connecting all the components. Connect all StrongPost® components together and insert into the Saddle Bracket pipe sleeve and onto the concrete base plate, leaving sufficient room for adjustment utilizing the 4.5" threaded rod adjustment length. Ensure the pipe is centered beneath the center of the joist or girder to be supported.
- G. Once the StrongPost® is in place, attach the saddle bracket to the new girder or existing floor joist utilizing the pertinent hardware supplied for the application. *Note: For single joists, utilize wood spacer blocking (see page 17). When affixing saddle bracket to a wooden girder, thru bolts are recommended (see page 18).*
- H. Once the StrongPost® system is in place, turn the adjusting nut on the threaded jacking rod, placing a stabilizing load upon the Polybase® to seat the foundation base against the soil. Release the load by backing the adjusting nut down until load is removed. Re-engage the load by turning the adjusting nut to the desired position of stabilization.
- I. After the load and positioning has been achieved, thread the jam nut down onto and against the top of the Jacking Cap surface to lock the load into place.

STRONGPOST® INSTALLATION

STRONGPOST® JOIST CONNECTION DETAILS

Saddle Bracket Application

StrongPost® Saddle Bracket is designed to accommodate the joist or beam utilizing a **2D Positive Connection**. The Saddle Bracket design can be used to affix the StrongPost® directly to multiple nominal 2X wooden floor joists, a single 2X nominal wooden floor joist with added blocking, or a wooden girder utilized to straddle support several wooden floor joists.

SADDLE BRACKET DETAIL FOR MULTIPLE WOOD JOISTS

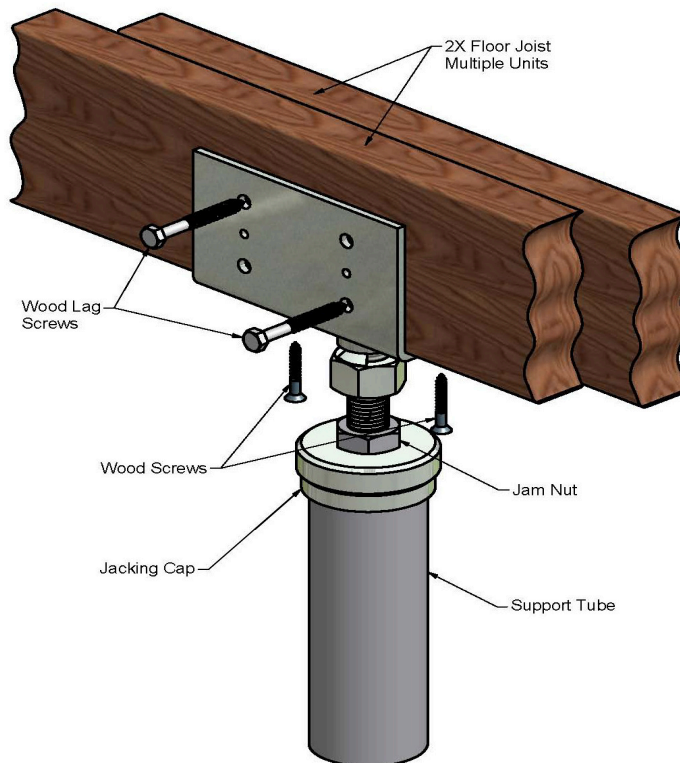

Multiple Wooden Joist Attachment:

Place the Saddle Bracket beneath the joists to be supported, C clamp the joists together and adjacent to the Saddle Bracket's final position and snug the Bracket's bottom plate up and against the bottom of the floor joist to be supported. Install the wood screws through the holes on the bottom of the saddle plate into the bottom of the joist to be supported. Once the wood screws have been installed, install the two lag screws provided in opposing diagonal holes through the vertical plate to affix the side of the Saddle Bracket. Release the C Clamps and load the StrongPost® to the desired point of stabilization. Adjust the jam nut into position as soon as the proper loading has been achieved, and lock into position.

SADDLE BRACKET DETAIL FOR SINGLE WOOD JOIST

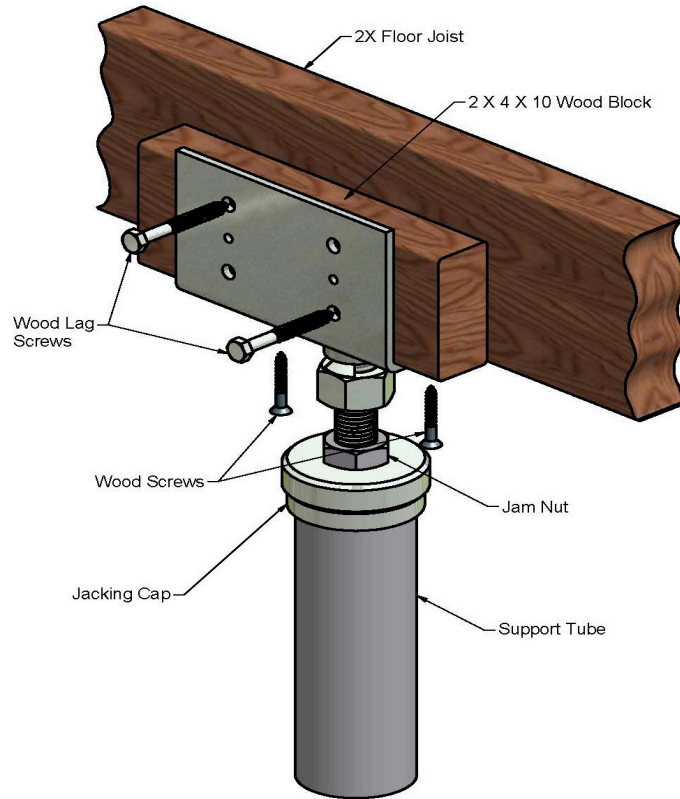

Single Wooden Joist Attachment:

When attaching the Saddle Bracket directly to a single joist, it is recommended to use a treated 2X4X10" wooden block between the side flange of the Saddle Bracket and the joist for a more rigid and centered connection. First place the wooden block into place and utilize two C-clamps to hold the joist and block in place during lag screw and wood screw installation. Snug the Saddle Bracket up against the floor joist and install two wood screws upward into the joist to be supported through the holes on the Saddle Bracket bottom plate. Next, install the two lag screws provided in opposing diagonal holes to affix the vertical side of the Saddle Bracket, making sure the lag screws have sufficiently penetrated both the block and the support joist. Release the C-clamps and load the StrongPost® to the desired point of stabilization. Adjust the jam nut into position as soon as the proper loading has been achieved and lock into position.

NOTE: Additional fasteners (not included) may be applied to the bracket during installation.



Attaching saddle bracket to block and single joist.



Tightening adjusting jam nut.

SADDLE BRACKET DETAIL FOR WOODEN GIRDER SUPPORT

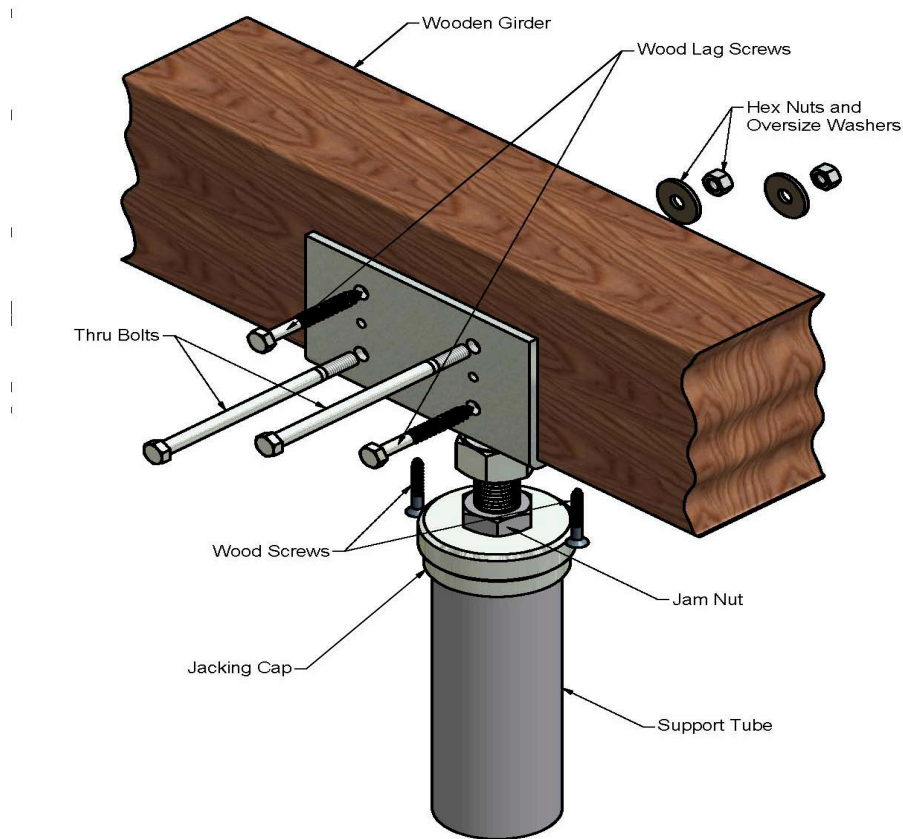

Wooden Girder Support Attachment:

When attaching the Saddle Bracket to a wooden support girder in support of multiple floor joists, fit the Saddle Bracket and StrongPost® into place and snug the bracket up and against the girder to be supported. Since wooden girders may vary in dimension, connection bolts are not provided. Once positioned, it is recommended to drill bolt holes through the girder at the point of post support, install the wood screws and lag screws provided. Install the screws through the bottom plate and into the girder making sure the vertical back plate is flush against the vertical side of the wooden girder. Secondly, install the lag screws provided and snug the vertical plate up against the side of the girder. Once the connection is completed, load the StrongPost® to the desired point of stabilization. Drill and insert (2) thru bolts through the larger holes in the side of the girder left vacant by the vertical plate of the saddle bracket and nut off the bolts with an oversized washer and nut. Complete the stabilization load required and adjust the locknut into position as soon as the proper loading has been achieved and lock into position.

Wooden Girder Span Support Application

Wood Girder Multi-Joist Span Support:

When mounting the StrongPost® 2D Positive Connection Saddle Bracket to the girder, affix the Saddle Bracket to the girder utilizing fasteners of choice (lag screws, lag bolts, or thru bolts). It is recommended to mount the 2D Positive Connection Brackets in alternating sequence for girder balance. Once the Saddle Brackets have been mounted and are in place beneath multiple joists, load and adjust each StrongPost® to accommodate the desired point of stabilization.

Top Plate Application

TOP PLATE SUPPORT FOR WOODEN FLOOR JOISTS

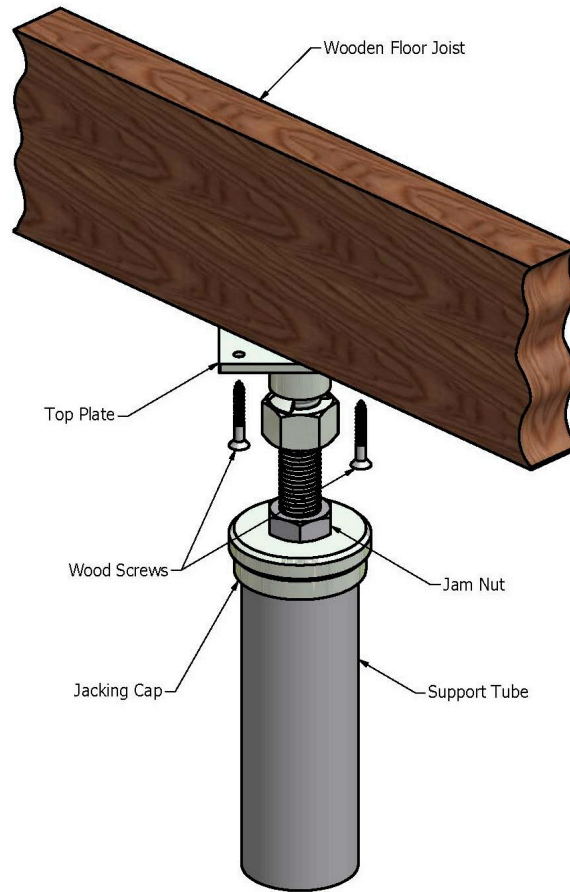

Top Plate Wooden Joist Support Attachment:

StrongPost® Top Plate is designed to accommodate a single or two joist support application. When utilizing the Top Plate Attachment, snug the Top Plate up against and directly underneath the joist(s) to be supported. Utilize woodscrews (optional) to attach the Top Plate to the floor joist. Once the Top Plate and StrongPost® components are assembled and in place, load the StrongPost® to the desired point of stabilization. Adjust the locknut into position as soon as the proper loading has been applied for stabilization and lock into position.



Metal I-Beam Girder Span Support Application

I-BEAM SADDLE BRACKET FOR METAL GIRDERS

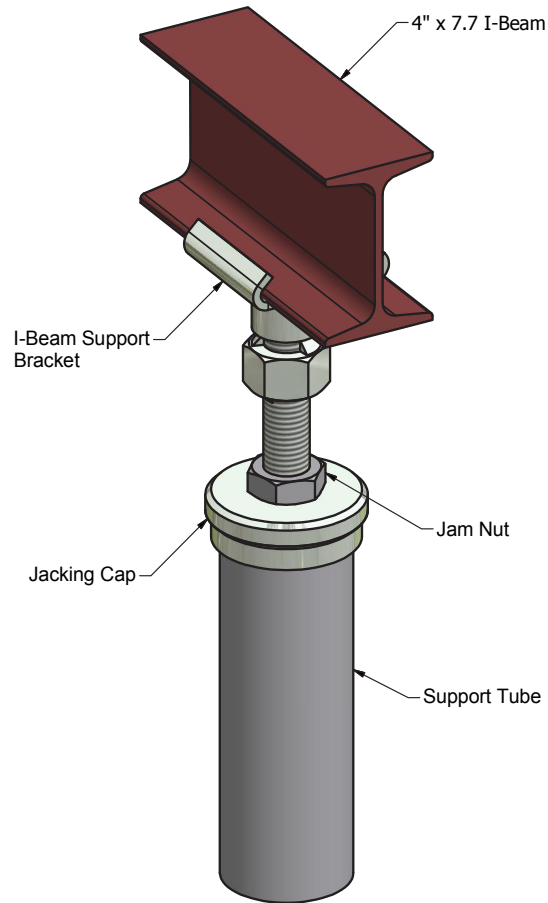

To install StrongPost® utilizing the Metal I-Beam Girder Connection, follow the top plate installation sequence on page 19.



STRDY

